

CLASS GUIDELINE

DNVGL-CG-0194

Edition December 2015

Hydraulic cylinders



FOREWORD

DNV GL class guidelines contain methods, technical requirements, principles and acceptance criteria related to classed objects as referred to from the rules.

© DNV GL AS December 2015

Any comments may be sent by e-mail to rules@dnvgl.com

If any person suffers loss or damage which is proved to have been caused by any negligent act or omission of DNV GL, then DNV GL shall pay compensation to such person for his proved direct loss or damage. However, the compensation shall not exceed an amount equal to ten times the fee charged for the service in question, provided that the maximum compensation shall never exceed USD 2 million.

In this provision "DNV GL" shall mean DNV GL AS, its direct and indirect owners as well as all its affiliates, subsidiaries, directors, officers, employees, agents and any other acting on behalf of DNV GL.

CHANGES – CURRENT

This is a new document.

CONTENTS

Changes – current.....	3
Section 1 General.....	5
1 Scope.....	5
2 Application.....	5
Section 2 Procedures.....	6
1 Approval procedure.....	6
Section 3 Design.....	8
1 General.....	8
2 Arrangement of hydraulic cylinders.....	8
3 Materials.....	9
4 Buckling.....	9
5 Cylinder tube and piston rod.....	12
6 End cover.....	12
7 Threaded connection.....	12
8 End eyes.....	13
9 Jigger winches.....	13
10 Welding.....	13
11 Nondestructive testing.....	14
12 Hydraulic cylinders for cranes and davits.....	15
13 Telescopic hydraulic cylinders.....	15
Section 4 Type testing for type approval.....	16
1 General.....	16
2 Type test for hydraulic cylinders for locking of cleats.....	16
3 Jigger winches.....	16
Section 5 Product certification.....	17
1 General.....	17

SECTION 1 GENERAL

1 Scope

This standard gives the requirements for which the Society bases the approval of hydraulic cylinders, including requirements for documentation, design, manufacturing and testing.

The procedure for assessment of conformity of manufactured products (production) is not part of the scope of this standard.

2 Application

This standard is applicable for hydraulic cylinders when referred to in the Society's rules or other relevant Society's standards

The Society reserves the right to deviate from the requirements in this document in connection with approval of hydraulic cylinders of special design or for specific applications.

SECTION 2 PROCEDURES

1 Approval procedure

Hydraulic cylinders required to comply with this standard shall either be case-by-case approved or type approved.

1.1 Case-by-case approval

Case-by-case approval procedure of hydraulic cylinders consists of the following elements:

- design assessment
- product certification.

Drawings and documentation shall be submitted to the Society's local office for each order.

1.1.1 Installed on objects classed with the Society

The drawings and documentation submittal shall include the following information:

- name of yard and building number or ship name/ID number for vessels in operation
- the task for the cylinder.

1.1.2 Installed on objects not classed with the Society

The drawings and documentation submittal shall include the following information:

- name of ship or rig
- name of project and copy of the original request for design approval in case of delivery to a land based project
- the task for the cylinder.

1.2 Type approval

Type approval is offered for identical products manufactured in series. Type approval is mandatory for hydraulic cylinders used for cleating service (hydraulic cylinders for cleating where the lock is placed inside the cylinder).

The type approval procedure consists of the following elements:

- design assessment
- product certification.

See the Society's document DNVGL CP 0338 - *Type approval scheme* for the general procedures regarding type approval. For retention and renewal of the type approval, a Society's surveyor shall perform a survey before the expiry of the certificate to verify that the conditions for the approval are complied with.

1.3 Documentation required

Together with the application for approval, the following documentation shall be submitted:

- Main drawings for all types and sizes. All dimensions necessary for calculating the strength of the pressure exposed parts such as all diameters and lengths and dimensional drawings of the terminations (if approval is wanted for the terminations) of the cylinder shall be stated on the drawings. Stroke, build-in lengths and clearing between piston/cylinder tube and piston rod/stuffing box shall be given. The dimensions may be tabulated on the drawings if convenient. The following shall be stated on the drawings:
 - information on whether it is a single or double acting cylinder. The corresponding design pressures for push and pull shall be given
 - how the cylinder is connected to or supported by the structure, preferably by a principle sketch

- reference to a design code
 - safety relief valve set pressure
 - test pressure
 - maximum and minimum design temperature.
 - threads: Diameter, pitch, lengths and tolerances.
 - corrosion allowances
 - exact designation of the materials used in all parts with reference to a recognized national/ international material standard. Information on gaskets/sealing shall also be given
 - extent of material testing, or type of material certificate for each material
 - reference to a welding procedure specification for each weld
 - extent and type of non-destructive testing of welds.
 - information on marking for identification/traceability.
 - factory testing procedures.
- For jigger winches: Drawings of sheave houses and wheels.
 - Calculation of the pressure exposed parts, cylinder terminations, flanges and threads.
 - Buckling calculation shall be submitted for pushing cylinders.
 - Test report(s) as required by this document.
 - A load curve giving the load over the stroke may be required.

1.4 Certification required

Hydraulic cylinders are subject to product certification as required by the applicable the Society's rules or standards for the cylinders. Alternatively a manufacturing survey arrangement may be established.

Requirements related to the product certification are given in [Sec.5](#) .

1.5 Hydraulic cylinders for cranes and davits

Cylinders for shipboard cranes that are not covered by class (**Crane** or **Crane vessel**) with a load carrying capacity not exceeding 20 tons, may be accepted with the manufacturers' certificate on the following conditions:

- the manufacturer is a recognized manufacturer, i.e. a manufacturer having passed an initial production audit
- the cylinder is subject to serial production, i.e. production of identical cylinders over a period of at least one to two months
- the exception may be agreed on a case-by-case basis and shall be agreed in advance
- design approval is mandatory
- extent of NDT and pressure testing shall be agreed in each case.

For hydraulic cylinders used in offshore cranes and platform cranes the Society's approval and certification is mandatory.

SECTION 3 DESIGN

1 General

The design of hydraulic cylinders shall be in accordance with this document, the Society's rules and/or other applicable standards.

2 Arrangement of hydraulic cylinders

Hydraulic cylinders may be designed with the following features:

- single or double acting
- with or without damping in one or both ends
- (self-) locking (mechanical) arrangements in one or both ends. An indicator to show the lock engagement may be fitted
- an over center valve providing hydraulic locking of the cylinder
- position indication in the piston rod
- different terminations. The most common termination is spherical bearings in each end, however, other types of terminations such as flanges, trunnion mountings and sheaves house(s) for wire operation (jigger winch cylinders) will also be accepted. The cylinder tube termination may be placed on the cylinder wall
- the piston rod may be externally guided
- end covers may be threaded or welded (or both) to the cylinder tube
- piston rod terminations may be threaded or welded (or both) to the piston rod
- piston rod may be of hollow or compact designs.

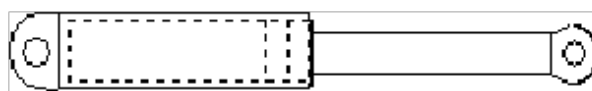

Figure 1 Spherical bearings in both ends

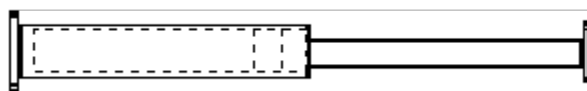

Figure 2 Flanged in both ends



Figure 3 Trunnion mounted

3 Materials

Materials for the cylinder tube, the piston rod and the end connections shall be delivered with material inspection certificate type 3.1 according to the latest edition of ISO 10474 or equivalent. The steel works is not required to be a Society approved steel manufacturer.

For material thickness 6 mm and above, impact testing shall be carried out at the prescribed temperatures, see [SHIP RU Pt.2 Ch.2 Sec.3](#). The average value from each set of three impact test pieces shall comply with the appropriate requirements in [RU SHIP Pt.2 Ch.2 Sec.3 Table 5](#) and Table 6, 7, 14, 15, and 17. Further, only one individual value within each set may be below the specified minimum average value, but not lower than 70% of this value.

Where the end cover is made from a rolled plate, the plate shall have through thickness (Z-direction) properties corresponding to quality class Z25 or better.

3.1 Hydraulic cylinders for steering gear/water jet steering

For cylinders intended for steering gear or water jet steering applications Charpy test is required. 3.2 material certificates are required for the cylinder tube and piston rod. 3.1 certificates are required for the end cover and piston. Reference is made to [RU SHIP Pt.4 Ch.10 Sec.1 Table 4](#).

3.2 Hydraulic cylinders for jacking systems for self-elevating units

End eyes of hydraulic cylinders used for elevating the unit shall follow material requirements outlined in the Society's document [DNVGL OS B101](#).

For casted end eyes, one piece per batch shall be proof load tested at design load.

4 Buckling

For the required buckling calculation for cylinders used for pushing, the following method may be used for control of buckling.

$$I_1 = \frac{\pi(D_o^4 - D_i^4)}{64} mm^4$$

$$I_2 = \frac{\pi(d_o^4 - d_i^4)}{64} mm^4$$

where:

- I_1 = moment of inertia for the cylinder tube, mm^4
- I_2 = moment of inertia for the piston rod, mm^4
- D_o = outer diameter of the cylinder tube, mm
- D_i = inner diameter of the cylinder tube, mm
- d_o = outer diameter of the piston rod, mm
- d_i = inner diameter of the piston rod, mm

$$Z = \frac{L_1}{I_1} + \frac{L_2}{I_2} + \left(\frac{1}{I_2} - \frac{1}{I_1} \right) \times \frac{L}{2\pi} \sin\left(2\pi \frac{L_1}{L} \right)$$

where.

- L_1 = visible length of the piston rod in fully extracted position from centre of its mounting, mm
- L_2 = length of the cylinder part from the centre of its mounting, mm

- L = length between mountings in fully extracted position ($L_1 + L_2$, mm).
See [Figure 4](#) and [Figure 5](#).

$$P_E = \frac{E \times \pi^2}{1000 \times L \times Z}$$

where:

P_E = buckling load, kN

E = Young's modulus of elasticity = $2.06 \cdot 10^5$ N/mm² for carbon steel.

The different lengths (cylinder tube length L_1 , rod length L_2 , Total length L) to be used in the buckling calculations are dependent on the fixation of the cylinder to the structure according to Euler theory as illustrated in the below 2 figures:

[Figure 4](#) shows fixation types qualifying for shortening the buckling length by $\sqrt{2}$. The right version needs to be calculated in 2 steps: one for the piston rod and one for the cylinder tube; each with buckling length = $\sqrt{2}$ of actual length.

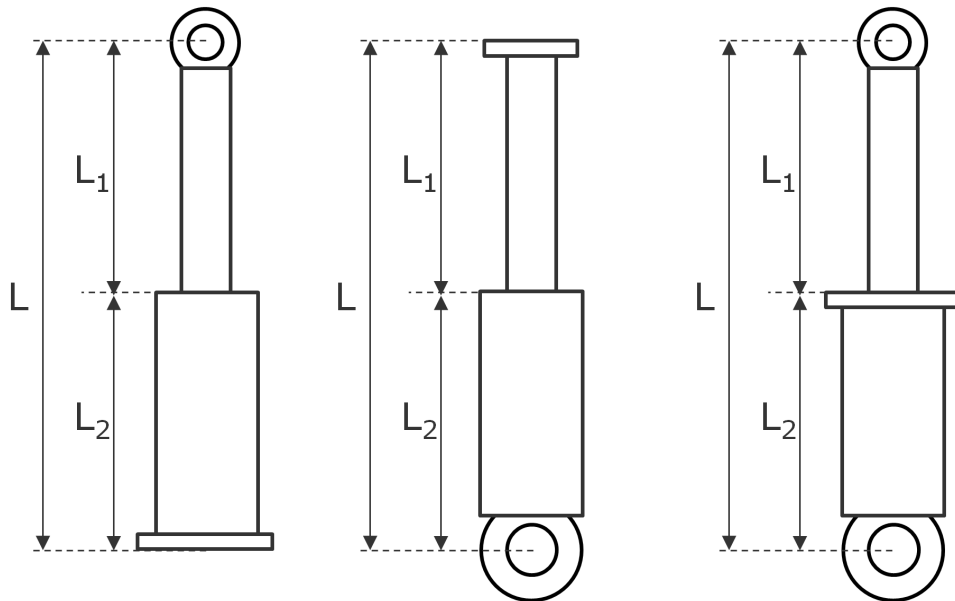

Figure 4

[Figure 5](#) shows fixation types qualifying for shortening the buckling length by 2. The right version needs to be calculated in 2 steps: one for the piston rod and one for the cylinder tube; each with buckling length = 0.5 of actual length.

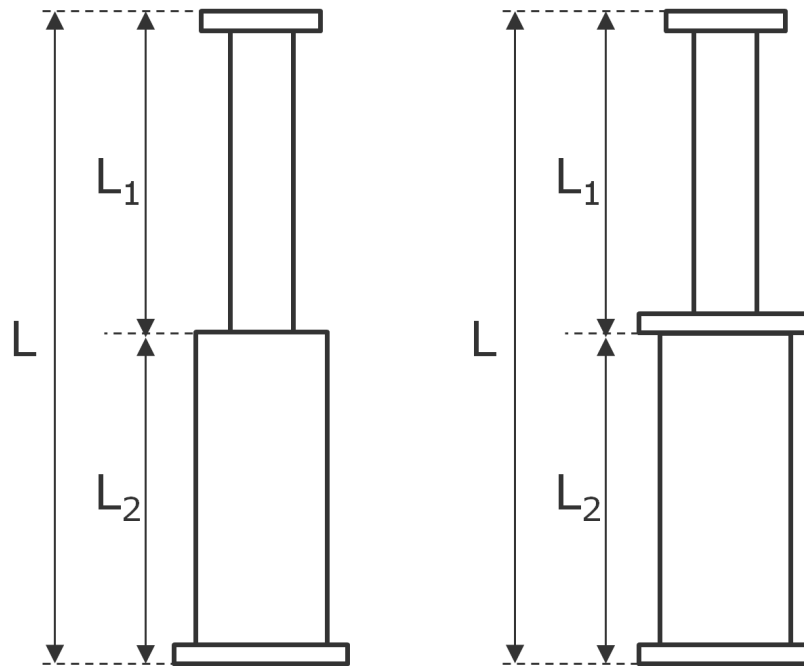

Figure 5

Acceptance criteria:

$$(P_E/P_a) \geq 4$$

where:

$$P_a = \text{actual maximum load} = \frac{\pi \cdot p}{4} \cdot D^2$$

$$P_E = \frac{\pi^2 \cdot E \cdot I}{2 \cdot L^2}$$

A lower buckling safety factor than 4.0 may be accepted for more accurate calculation methods. In that case the method shall be approved separately by the Society. Relevant parameters which may be included in such a method are:

- yield strength of piston rod material
- bending moments caused by the rotation of the mounting bearings
- guiding length
- clearance between gland and piston rod
- actual deflection curve.

However, the lowest acceptable safety factor will normally not be less than 2.7 regardless of calculation method.

Concerning buckling calculations of hydraulic cylinders for cranes reference is made to the Society's standard for shipboard lifting appliances, DNVGL [ST 0377](#) and the Society's standard for offshore and platform lifting appliances, DNVGL [ST 0378](#).

Scantlings of hydraulic cylinders shall comply with the requirements in the Society's rules for ships.

5 Cylinder tube and piston rod

The cylinder tube, the hollow piston rods with pressure in rod and the end cover shall be dimensioned according to a recognized standard. The wall thickness of the cylinder tube and hollow piston rods with pressure in the rod shall be dimensioned according to the following:

$$t = \frac{p \cdot R}{10 \cdot \sigma_t \cdot e - 0.5 \cdot p} + c$$

where:

- t = required wall thickness, mm
- p = design pressure, bar
- R = internal cylinder tube radius, mm
- σ_t = allowable stress, design stress, N/mm²
- e = welding factor = 1 for seamless pipes
- c = corrosion allowance, usually 0.3 mm.

End covers and bolts/tie rods shall be dimensioned according to Society's rules or a recognized international standard.

6 End cover

The strength of the end cover is to be documented according to a recognized standard such as EN14359 or equivalent.

See [10] for requirements to the steering edge and the weld between the end cover and the cylinder tube.

7 Threaded connection

Threads shall be calculated according EN 14359 or equivalent. When threaded end covers and/or stuffing boxes are used the flaring effect on the cylinder tube can be found from recognized codes (EN 14359 or equivalent). This will be applicable for bigger diameter cylinders ($\geq \text{Ø}350$ mm inner tube diameter) If compliance with the requirements in the standard is not achieved the end cover/stuffing box will have to be bolted to the cylinder tube. Care shall be taken so the depth of the bolt holes do not extent beyond the sealing in the stuffing box. Alternatively a flange needs to be fitted on the tube end.

7.1 Threaded connection acting as sealing

Parallel threads, which shall provide sealing against leakage to the outside on different parts of a hydraulic cylinder, shall be provided with O-ring seals or equivalent. The O-ring material shall be specified and shall be suitable for the intended purpose.

7.2 Other sealing arrangements

The material used in sealings shall be specified and shall be suitable for its intended purpose with good sealing properties and proper resistance against the hydraulic fluid. A statement from the seal manufacturer or a test report may be required. Sealing between the stuffing box and the cylinder tube shall be positioned in the stuffing box at least 2 mm away from the threaded part of the cylinder tube on the straight tube and shall consist of an O-ring with support ring(s).

8 End eyes

8.1 End eyes for traction cylinders

The highest stresses in the end eyes for traction use will appear along the contact surface between the bearing and the end eye. The tension shall be calculated according to the following:

$$\sigma_t = \frac{F}{T \cdot (D-d)} \sqrt{\frac{D^2}{d^2} - \frac{D}{d} + 1} \leq \sigma_y$$

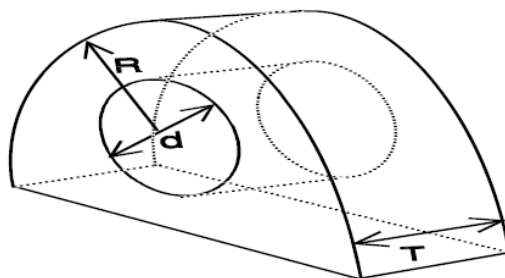

Figure 6 End eye

where:

- F = cylinder traction force, N
- T = width of end eye, mm
- D = outer diameter of end eye = $2 R$ in [Figure 6](#), mm
- d = inner diameter of end eye (outside bearing), mm
- σ_y = yield strength of the end eye material, N/mm².

9 Jigger winches

Sheave houses and bolt(s) for the wheel(s) are subject to design approval and shall be submitted together with the drawings for the hydraulic cylinder. The direction of the wire entry and exit from the wheels and the wire force shall be given. All welds on a sheave house shall be welded from one side and shall be executed as full penetration welds.

10 Welding

Any welding procedure specification need to be qualified and all welding shall be performed by a certified welder. Filler metals shall be of approved type. The welding procedure specifications shall be qualified.

Welded butt joints and welds for oil supply studs and branches shall be of full penetration type including welds for pipes forming a part of the hydraulic cylinder, particularly for oil inlet pipes. Welding production test may be required for thicknesses > 38 mm. Preheating shall be used when necessitated by the dimensions and the material composition. Further reference is made to relevant parts of the Society's rules for ships.

Oxy-acetylene welding is not to be used for cylinder diameters greater than 102 mm or wall thickness exceeding 10 mm.

Welds on sheave houses for jigger winches are subject to dye penetrant examination or magnetic particle inspection, MT.

Repair welding shall be carried out in accordance with approved welding procedure specification.

All welds shall be full penetration welds. For the weld between the end cover and the cylinder tube, and also for the oil supply studs, the length of the steering edge (unwelded section) is allowed to be max. 3 mm long. It shall be small enough to be burned away during welding. Non-compliance with this requirement will limit the approved number of operating cycles to 15 000 over the life span. Alternatively the fatigue strength of the connection may be documented by finite element analysis or other recognized calculation methods.

The steering edge is the portion of the end cover entering the tube in order to center the end cover relative to the tube before welding. See [Figure 7](#).

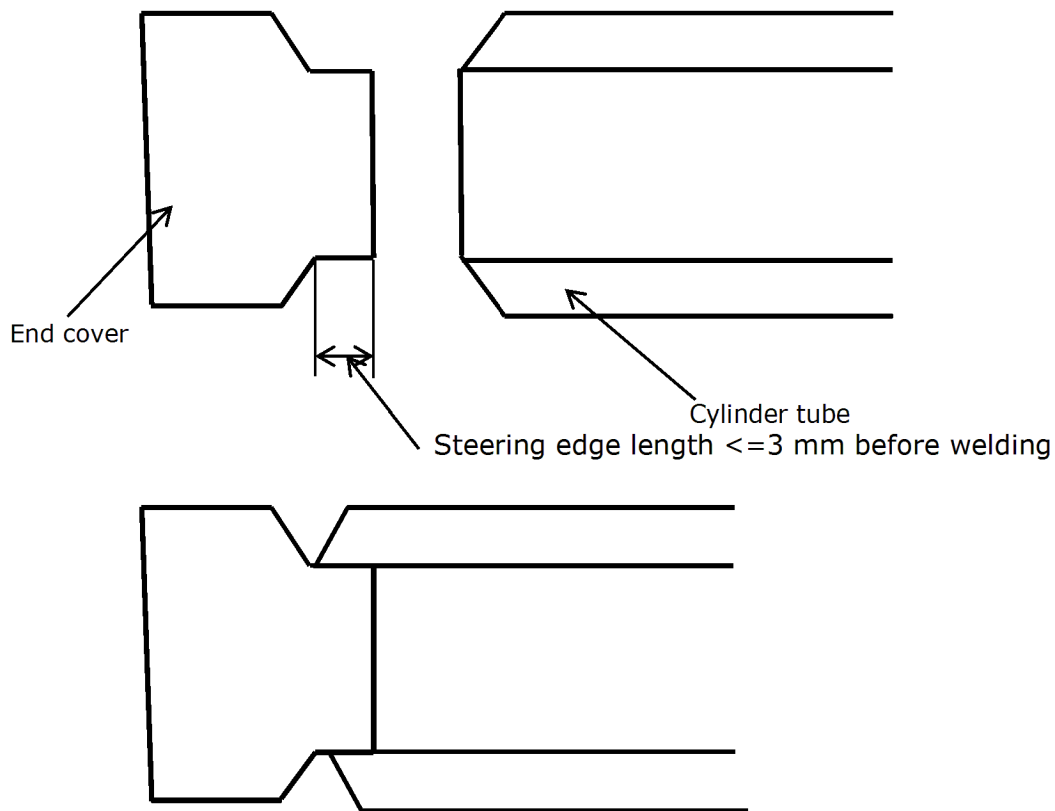

Figure 7 Steering edge on the end cover

11 Nondestructive testing

All welds shall be subjected to 100% NDT including Visual inspection (VT), Magnetic particle testing (MT) for ferro magnetic materials, or penetrant testing (PT) for non-ferro magnetic materials. Ultrasonic or radiographic testing shall be applied for detecting sub-surface indications, see the Society's class guideline CG 0051 *Non-destructive testing*.

12 Hydraulic cylinders for cranes and davits

The design calculations submitted for approval shall be based on the maximum obtainable pressure. Alternatively, if the maximum dynamic force applied on the crane is known, this may be used as basis for the design calculations. Different outreach positions may have to be evaluated. Based on individual considerations, a buckling safety factor down to 2.3 may be accepted for more accurate calculation methods than the one given in [4]. For the Society to accept such a method it has to be separately approved.

Materials shall fulfil the requirements given in [3].

Requirements regarding cylinder wall thickness are described in [5]. Welds shall be full penetration welds. Other weld geometries than full penetration welds may be accepted on a case-by-case basis provided that acceptable stresses (both with respect to fatigue and static strength) can be documented. This will primarily be applicable for cylinders used for pushing only (e.g. jib cylinders).

13 Telescopic hydraulic cylinders

Telescopic hydraulic cylinders are hydraulic cylinders with more than one piston rod. The benefit of telescopic cylinders is that they are relatively small in length at zero stroke compared to the max stroke.



In addition to performing control calculation of the strength of the different piston walls against the internal pressure these cylinders shall also be calculated for buckling [4] as follows:

- the biggest pipe is designated to be the cylinder tube
- calculate the moment of inertia for each pipe forming the rod
- add the sum of the moments of inertia for each rod
- find the corresponding compact rod by solving the equation for d_o .

This d_o shall be used in the formula in [4] with $d_i = 0$ (zero).

SECTION 4 TYPE TESTING FOR TYPE APPROVAL

1 General

Type testing is applicable for hydraulic cylinders to be type approved. Type approval of hydraulic cylinders is normally not required except for hydraulic cylinders for locking of cleats. Hydraulic cylinders for locking cleats shall be type tested according to [2]. The test procedure for type testing of other hydraulic cylinders will be agreed upon in each case.

2 Type test for hydraulic cylinders for locking of cleats

2.1 Endurance test

The test procedure shall be approved by the Society before commencement of the test. The test shall be performed with the test object in horizontal position. The lock shall be engaged and disengaged for 1500 cycles. One cycle shall include one engaging and one disengaging. The lock shall be activated with hydraulic oil through the oil supply studs at the cylinder design pressure during this test. The cylinder lock shall be pre-stressed with an external load corresponding to 5% of the design load. One sample of each cylinder size/lock type shall be tested; i.e. a lock placed at the stuffing box does not qualify a lock placed at the opposite end. After the testing the cylinder shall be dismantled for inspection of all the different parts of the lock. No loss of material or visible deformation is allowed upon completion of the test. All parts of the lock shall be subjected to an MT test and shall have zero indication of cracks. The test shall be witnessed by a Society's surveyor who shall sign the test report.

2.2 Static strength test

One sample of each cylinder size /lock type shall be tested, i.e. a lock placed at the stuffing box does not qualify a lock placed at the opposite end.

- Pressurize the cylinder to 80% of the design pressure.
- With an external force test the lock for proper engagement.
- Increase the pressure 20% and retest the lock for proper engagement.
- Continue the increase of pressure in steps of 20% until the lock fails to engage.

After the testing the cylinder shall be dismantled for inspection of all the different parts of the lock.

The lock shall not fail to engage until the pressure has reached 200% of the design pressure. No loss of material or visible deformation is allowed upon completion of the test. All parts of the lock shall be subjected to an MT test and shall have zero indication of cracks. The test shall be witnessed by a Society's surveyor who shall sign the test report.

3 Jigger winches

Sheave houses and bolt(s) for the wheel(s) are subject to design approval and shall be submitted together with the drawings for the hydraulic cylinder. The direction of the wire entry and exit from the wheels and the wire force shall be given. All welds on a sheave house shall be welded from one side and shall be executed as full penetration welds.

SECTION 5 PRODUCT CERTIFICATION

1 General

Product certification shall not take place before approved drawings are made available to the Society's surveyor. In case of a short delivery time where stamped drawings are non-existent at the time of product certification, a written confirmation that the cylinder drawings will be approved shall be at hand from the approval body. The product certification procedure consists of the following:

- review of material certificates
- review of welder's qualification certificates
- review of the welding procedure specification
- review of reports from nondestructive testing of welds
- dimensional check of critical measures
- hydraulic pressure testing/functional testing.

A product certificate where the results from the required tests are given will be issued and shall accompany each cylinder/delivery. The certificate will give unique identification of the cylinders. The approved drawings for the design will be listed as well as information on where the cylinders shall be installed.

1.1 Material certificates

The requirements to material certificates are given in [Sec.3 \[3\]](#).

1.2 Welding

The requirements to welding are given in [Sec.3 \[10\]](#).

1.3 Nondestructive testing

The requirements to NDT are given in [Sec.3 \[11\]](#).

1.4 Dimensional check

Measures such as zero stroke/maximum stroke and other measures considered vital/critical shall be verified against approved drawings.

1.5 Hydraulic pressure testing

Hydraulic cylinders shall be hydraulically pressure tested to minimum 1.3 times the design pressure alternatively 1.3 times the safety relief valve set pressure, whichever is the greatest, before paint or any coating is applied on the cylinders. The test pressure shall be applied to both sides of the piston head in sequence.

For hydraulic cylinders for steering gear and water jet steering the test pressure shall be 1.5 times the design pressure. For hydraulic cylinders for reversing of water jets the test pressure is 1.3 times the design pressure.

No leakage from or permanent deformation of any part shall occur.

1.6 Testing of hydraulic locking cylinders

The following test shall be carried out for hydraulic locking cylinders:

- engage the lock

- release the pressure and apply an external load on the piston rod corresponding to 50% of the design pressure in the direction where the lock takes up the force. Apply the force for 1 minute
- release the force and perform the below hydraulic function test of the lock.

The rod shall be kept in locked position without the hydraulic pressure applied. The lock shall disengage by applying hydraulic pressure below the design pressure.

For hydraulic locking cylinders equipped with inductive switches for control of locked and unlocked position the following apply in addition: The function of the switches shall be checked by connecting a test lamp to the switch and driving the cylinder in and out of the locked position 10 times.

1.7 Marking

Hydraulic cylinders shall be permanently marked in order to enable unique traceability to a product certificate or a type approval certificate. The marking shall at least consist of the following:

- manufacturers name or trade mark
- type designation
- charge number for the materials used in the cylinder tube and the piston rod.

Additional marking may be done at the manufacturer's option.

DNV GL

Driven by our purpose of safeguarding life, property and the environment, DNV GL enables organizations to advance the safety and sustainability of their business. We provide classification and technical assurance along with software and independent expert advisory services to the maritime, oil and gas, and energy industries. We also provide certification services to customers across a wide range of industries. Operating in more than 100 countries, our 16 000 professionals are dedicated to helping our customers make the world safer, smarter and greener.

SAFER, SMARTER, GREENER